

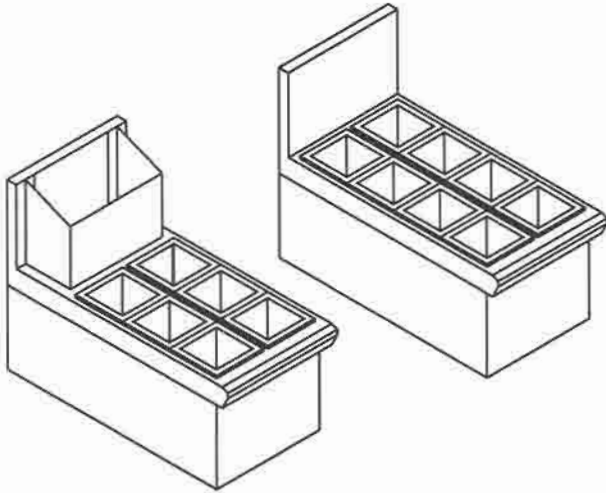

Insulated Bottle Storage Chests

can be used for potable ice



PROJECT _____
 ITEM NO. _____
 QTY. _____

"S" SERIES (20 1/2" DEEP)

	MODEL	LENGTH	WELLS	CHASE
<input type="checkbox"/>	SBCI-3	7"	3	--
<input type="checkbox"/>	SBCI-6	12"	6	--
<input type="checkbox"/>	SBCI-3C	7"	3	6x6"
<input type="checkbox"/>	SBCI-6C	12"	6	6x12"

"C" at end of part # indicates models with beverage chase and chimney at rear

"D" SERIES (24" DEEP)

	MODEL	LENGTH	WELLS	CHASE
<input type="checkbox"/>	DBC1-4	7"	4	--
<input type="checkbox"/>	DBC1-8	12"	8	--
<input type="checkbox"/>	DBC1-4C	7"	4	6x6"
<input type="checkbox"/>	DBC1-8C	12"	8	6x12"

If insulated chest is not required, drop I after C in part # example: SBCI-6 (see model guide below)

STANDARD FEATURES

- **ALL WELDED CONSTRUCTION** - fully welded, ground and polished to form one integral unit; no screws, pop-rivets or solder.
- **TOP** - 18 gauge #304 series 18-8 stainless steel.
- **FRONT APRON** - 18 gauge #304 series 18-8 stainless steel.
- **BACK** - 18 gauge #304 series 18-8 stainless steel.
- **BOTTOM** - 18 gauge #304 series 18-8 stainless steel.
- **ENDS** - 18 gauge #304 series 18-8 stainless steel.
- **BACKSPLASH** - 18 gauge #304 series 18-8 stainless steel.
- **ICE CHEST LINER** - 8" net deep, 18 gauge #304 series 18-8 stainless steel all welded.
- **INSULATION** - polyurethane shot-in-place foam (NO CFC's).
- **BOTTLE WELL ASSEMBLIES** - individual polypropylene bottle wells drop into chest

OPTIONS

- CB** -----full cabinet base with removable hinged doors
- BN** -----decorative polished bullnose
- M** -----customized

Model Number Guide

Use this guide to create the model specific to your needs.

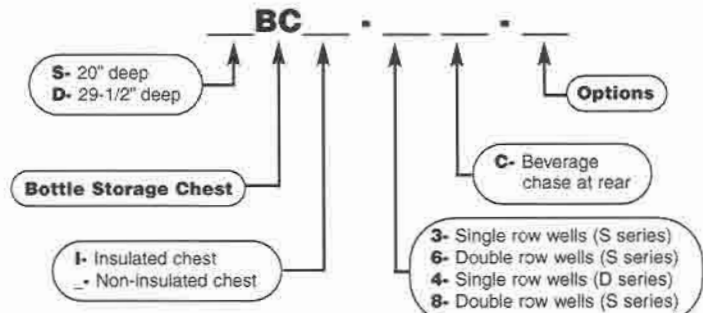



BCI MODELS

Insulated Bottle Storage Chests

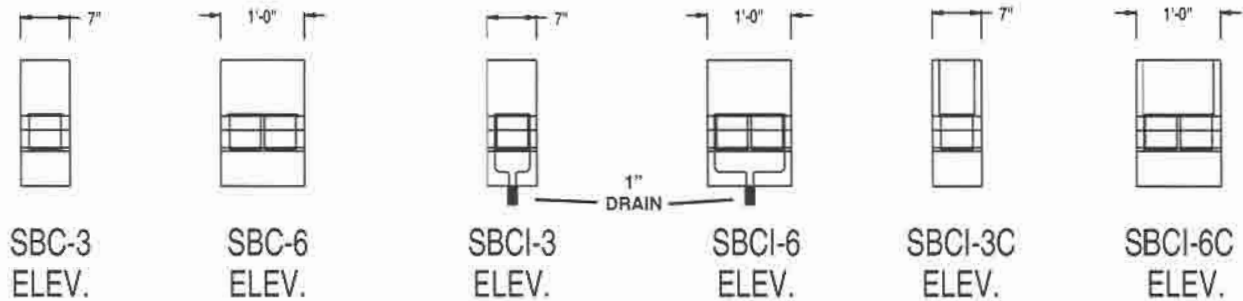
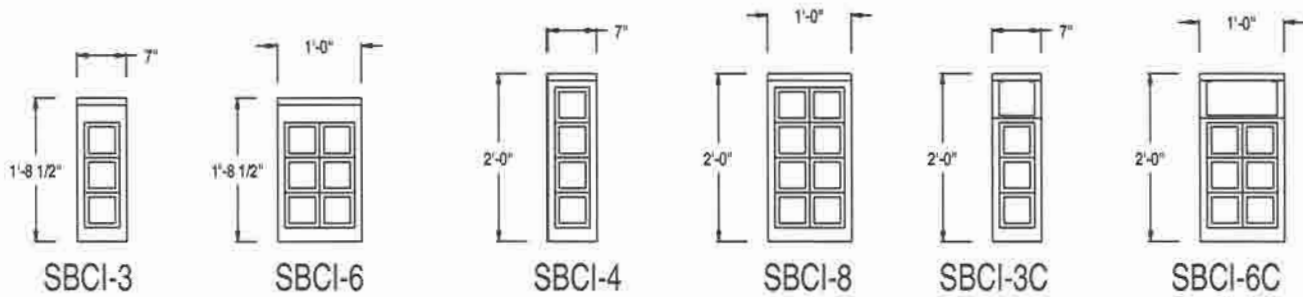
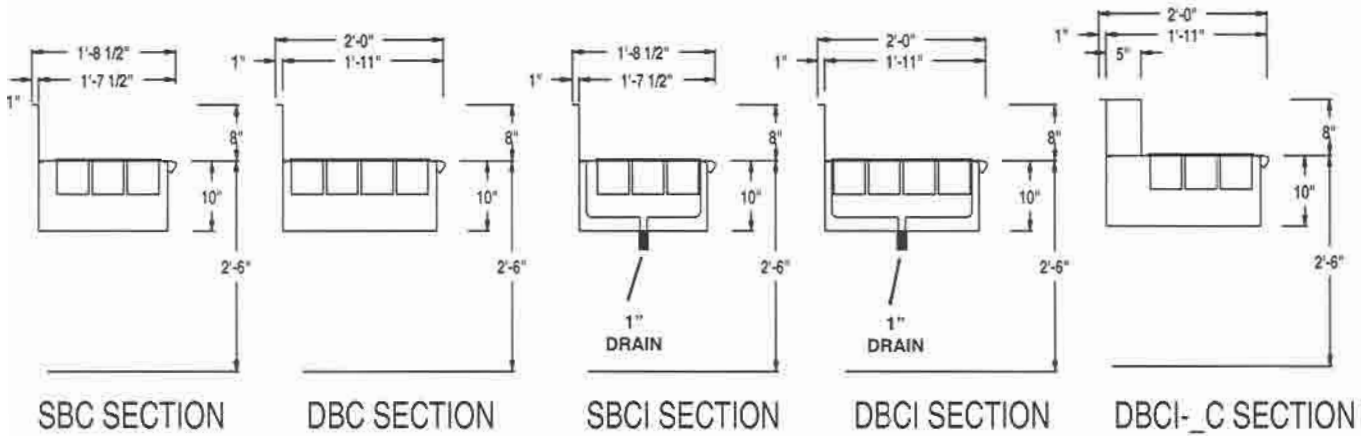

STORAGE CHESTS LESS BEVERAGE CHASE

"S" SERIES					"D" SERIES					SHIP WEIGHT	CUBE
MODEL	LENGTH	DEPTH	WELLS	CHASE	MODEL	LENGTH	DEPTH	WELLS	CHASE		
SBCI-3	7"	20 1/2"	3	---	DBCI-3	7"	24"	4	---	55	4
SBCI-6	12"	20 1/2"	6	---	DBCI-3	12"	24"	8	---	65	9

STORAGE CHESTS WITH BEVERAGE CHASE & CHIMNEY AT REAR

SBCI-3C	7"	24"	3	6"X6"	DBCI-3C	7"	29-1/2"	4	6"X6"	65	5
SBCI-6C	12"	24"	6	6"X12"	DBCI-3C	12"	29-1/2"	8	6"X12"	75	10