

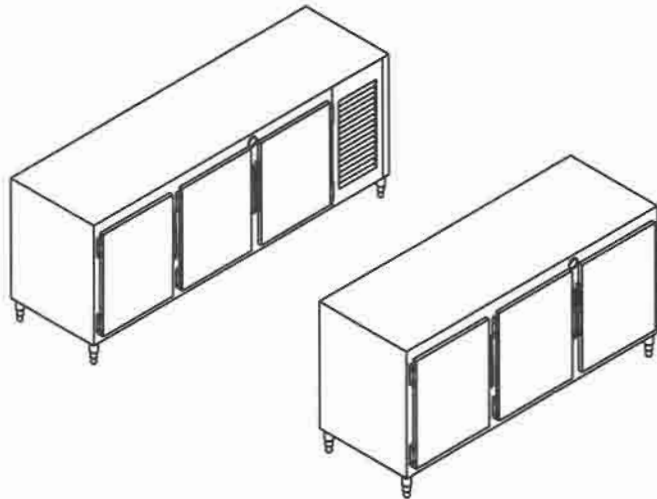

CH MODELS

Counter High Refrigerators w/Doors



PROJECT _____

ITEM NO. _____

QTY. _____

	REMOTE			SELF-CONTAINED		
	SECTIONS	DOORS	LENGTH	MODEL	LENGTH	MODEL
<input type="checkbox"/>	1	1	26"	CHR-1	42"	CHS-1
<input type="checkbox"/>	2	2	51"	CHR-2	67"	CHS-2
<input type="checkbox"/>	3	3	76"	CHR-3	92"	CHS-3
<input type="checkbox"/>	4	4	101"	CHR-4	117"	CHS-4

For combination doors and drawers, indicate number of each after dash, example: LRR-1-02-1 for a 3 section unit with one door on the left, two drawers in the center and one door on the right.

Integrating to custom-fabricated counter - Omni will provide custom fabricator with a detailed shop drawing which will illustrate how to fabricate top so it will easily interface with base.

STANDARD FEATURES

- **ALL WELDED CONSTRUCTION**
- **TOP** - reinforced with 14 gauge integrated galvanized "U" channels and 18 gauge galvanized sub-top.
- **EXTERIOR** - exterior front and sides are 20 gauge #304 stainless steel. Back and bottom are 18 gauge galvanized.
- **INTERIOR** - liner is 20 gauge #304 stainless steel with 3/8 inch radius corners.
- **DOORS** - 18 gauge front and 20 gauge door pan #304 18-8 stainless steel with polyurethane shot-in-place foam insulation. Non-magnetic, high compression, long life vinyl gasket. Kason edge mount self-closing hinges and locking door latch.
- **INSULATION** - 2" thick polyurethane shot-in-place foam (NO CFC's)
- **BREAKER STRIP** - Exclusive Foam-Locked breaker strip permanently installed without mechanical fasteners.
- **SHELVING** - Each door section includes two adjustable, vinyl coated wire racks.
- **SELF-CONTAINED REFRIGERATION** - fully balanced hermetic condensing unit is provided with evaporator coil, TX valve, thermostat, air defrost system and condensate evaporator. Condensing unit will be on right unless otherwise specified.
- **REMOTE MODELS** - include all of the above with the exception of condensing unit and condensate evaporator pan. Expansion valve shipped loose. No pre-wiring.
- **DIAL THERMOMETER**
- **INTERIOR LIGHTS**

OPTIONS

- (02)** -----two drawer high section (see model guide)
- (03)** -----three drawer high section (see model guide)
- MDS3** -----exclusive three pan drawer
- TP** -----finished 14 gauge s/s top
- 6LG** -----6" x 1-5/8" stainless steel legs with adjustable bullet feet
- CST** -----casters
- SSE** -----full stainless steel ends
- AS** -----full stainless steel back and bottom
- SSS** -----stainless steel shelves
- PS** -----pan slides
- NB** -----narrow 24" deep body
- F** -----freezer
- EVP** -----condensate evaporator (remote only)
- DT** -----dual temp
- GL** -----glass doors
- M** -----customized
- PP** -----Pre-piped & pre-wired. Refrigeration, plumbing and electrical will be stubbed out at required location by specifying one of the following: LE-left end, RE-right end, BL-back left, BR-back right.

Model Number Guide

Use this guide to create the model specific to your needs.

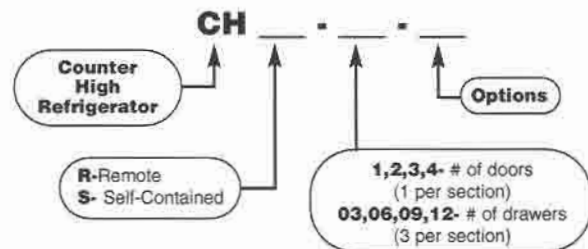



CH MODELS

Counter High Refrigerators w/Doors

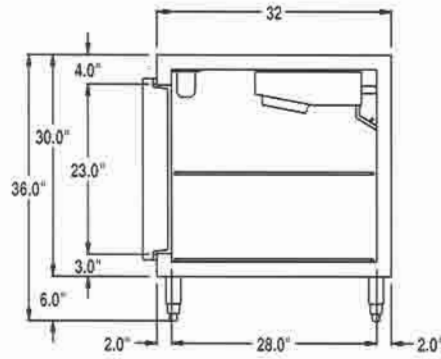

SECTION

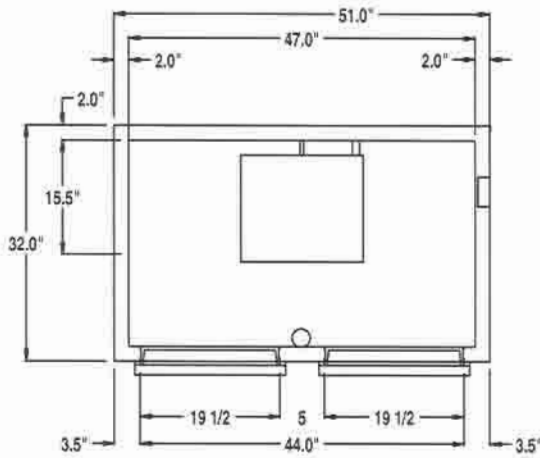

CHR-2

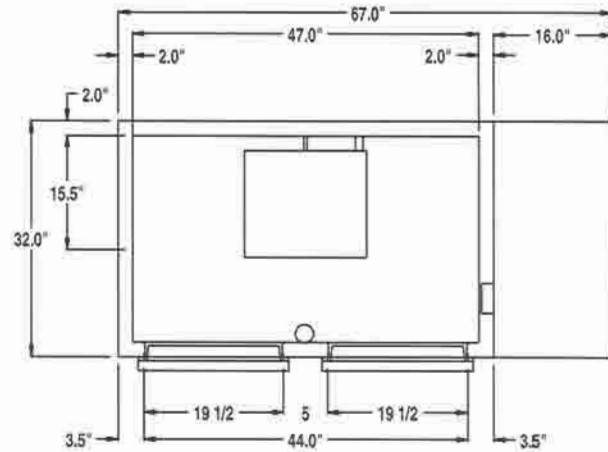

CHS-2

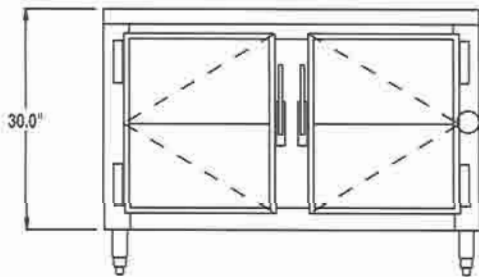

ELEVATION

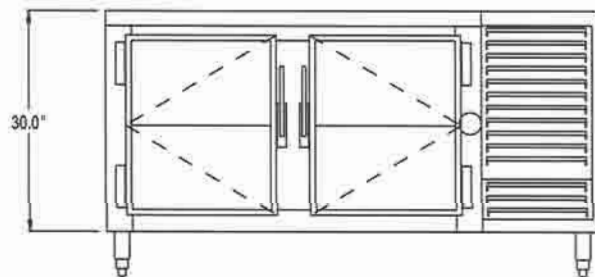

ELEVATION

MODEL	DOOR	O.A. CABINET DIMENSIONS			COMPRS.	ELECTRICAL			SHIP		
	SECTIONS	LENGTH	DEPTH	HEIGHT	HP.	AMPS	VOLTAGE	PHASE	BTUs	WEIGHT	CUBE
CHR-1	1	26"	32"	30"	—	1.6	115v	SINGLE	1000	240	16
CHR-2	2	51"	32"	30"	—	3.1	115v	SINGLE	2000	380	30
CHR-3	3	76"	32"	30"	—	3.6	115v	SINGLE	2625	510	44
CHR-4	4	101"	32"	30"	—	4.1	115v	SINGLE	3000	775	60
CHS-1	1	42"	32"	30"	1/4	9.1	115v	SINGLE	—	330	25
CHS-2	2	67"	32"	30"	1/3	1.1	115v	SINGLE	—	470	39
CHS-3	3	92"	32"	30"	1/2	13.9	115v	SINGLE	—	600	53
CHS-4	4	117"	32"	30"	1/2	13.9	115v	SINGLE	—	865	68

SELF CONT. REMOTE