

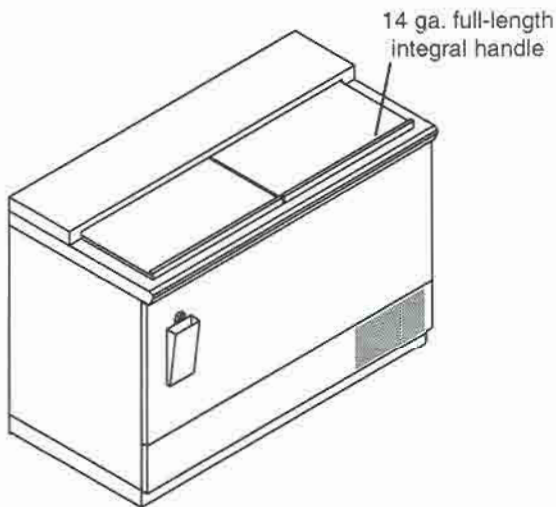

# FTB MODELS

## Flat Top Bottle Coolers



PROJECT \_\_\_\_\_  
 ITEM NO. \_\_\_\_\_  
 QTY. \_\_\_\_\_  
 MODEL NO. \_\_\_\_\_

	LENGTH	DOORS	SELF-CONTAINED		REMOTE
			MODEL	ALL S/S	MODEL
<input type="checkbox"/>	24"	1	FTBS-24	FTBS-24AS	FTBR-24
<input type="checkbox"/>	36"	1	FTBS-36	FTBS-36AS	FTBR-36
<input type="checkbox"/>	48"	2	FTBS-48	FTBS-48AS	FTBR-48
<input type="checkbox"/>	72"	2	FTBS-72	FTBS-72AS	FTBR-72

### STANDARD FEATURES

- **ALL WELDED CONSTRUCTION**
- **TOP** - 18 gauge #304 series 18-8 stainless steel.
- **EXTERIOR BODY** - exterior front, sides, back and bottom are 20 gauge stainless steel.
- **INTERIOR** - liner is 20 gauge #304 stainless steel with 3/8 inch radius corner. Sanitation approved for open food containers.
- **DECORATIVE POLISHED BULLNOSE** - 18 gauge #304 s/s.
- **MEGABILT SLIDING LIDS** - all 14 gauge welded #304 18-8 stainless steel with polyurethane shot-in-place foam insulation. Lids easily slide open and closed with exclusive, centered, 14 gauge s/s integral pull with lifetime warranty. Locks provided.
- **BASE PLINTH** - 2-1/2" high 18 gauge #304 18-8 stainless steel base.
- **INSULATION** - 2" thick polyurethane shot-in-place foam (NO CFC's)
- **BREAKER STRIP** - Exclusive Foam-Locked breaker strip permanently installed without mechanical fasteners.
- **PARTITIONS** - adjustable vinyl coated wire partitions.
- **SELF-CONTAINED REFRIGERATION** - R-134A fully balanced hermetic condensing unit is provided with evaporator coil, TX valve, thermostat, gravity defrost system and condensate evaporator.
- **REMOTE MODELS** - include all of the above with the exception of condensing unit and condensate evaporator pan. Refrigeration, plumbing and electrical will be stubbed out at required location by specifying one of the following: LE-left end, RE-right end, BL-back left, BR-back right. Please advise refrigerant type.
- **BOTTLE OPENER W/ CAP CATCHER**
- **INTERIOR LIGHT**

### OPTIONS

- BS** -----backsplash
- CST** -----casters
- 6LG** -----6" x 1-5/8" stainless steel legs with adjustable bullet feet
- BRS-(XX)**- Speed rail (XX=length in inches)
- M**-----customized

### Model Number Guide

Use this guide to create the model specific to your needs.

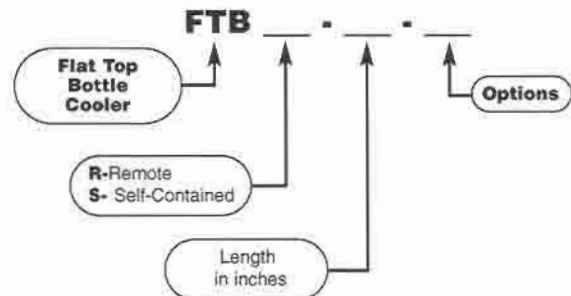



**FTB MODELS**

*Flat Top Bottle Coolers*



FTBS-24

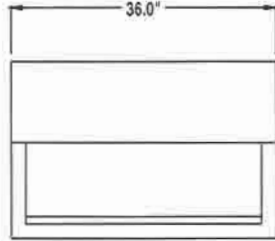

FTBS-36

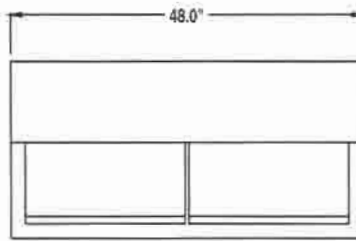

FTBS-48

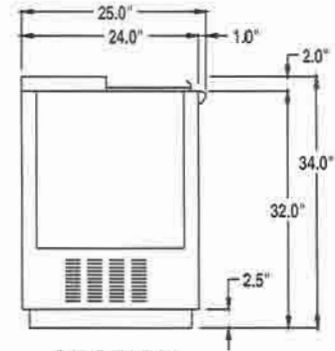

SECTION

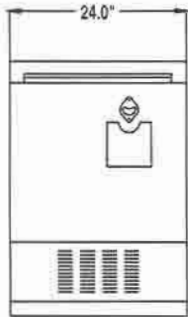

ELEVATION

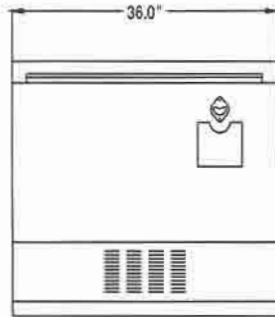

ELEVATION

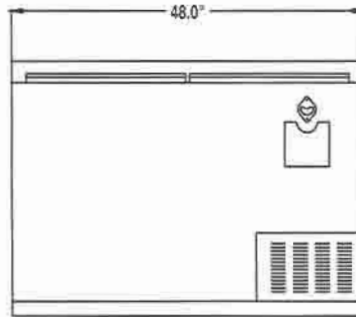

ELEVATION

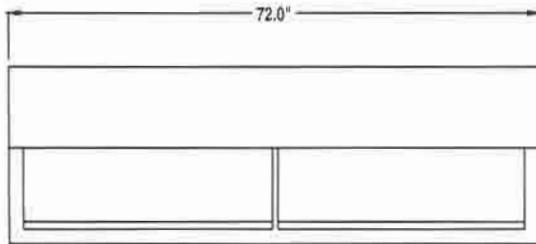

FTBS-72

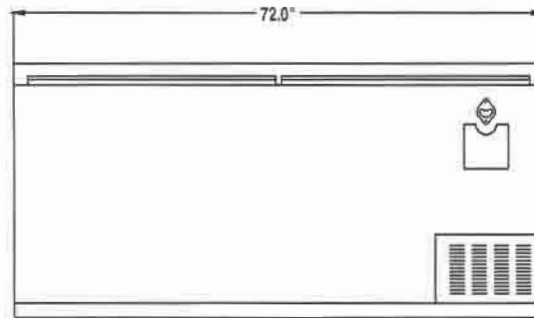

ELEVATION

REMOTE ALL S/S STANDARD

MODEL	O.A. DIMENSIONS			CASE CAP.	CMPRSR. HP.	ELECTRICAL			BTUs	SHIP	
	LENGTH	DEPTH	HEIGHT			AMPS	VOLTAGE	PHASE		WEIGHT	CUBE
FTBS-24	24"	25"	34-1/2"	6	1/4	7.1	115	SINGLE	—	185	15
FTBS-36	36"	25"	34-1/2"	13	1/4	7.1	115	SINGLE	—	260	22
FTBS-48	48"	25"	34-1/2"	20	1/3	9.5	115	SINGLE	—	335	29
FTBS-72	72"	25"	34-1/2"	43	1/3	9.5	115	SINGLE	—	475	43
FTBS-24AS	24"	25"	34-1/2"	6	1/4	7.1	115	SINGLE	—	185	15
FTBS-36AS	36"	25"	34-1/2"	13	1/4	7.1	115	SINGLE	—	260	22
FTBS-48AS	48"	25"	34-1/2"	20	1/3	9.5	115	SINGLE	—	335	29
FTBS-72AS	72"	25"	34-1/2"	43	1/3	9.5	115	SINGLE	—	475	43
FTBR-24	24"	25"	34-1/2"	9	—	—	—	—	1000	185	15
FTBR-36	36"	25"	34-1/2"	16	—	—	—	—	1200	260	22
FTBR-48	48"	25"	34-1/2"	23	—	—	—	—	1500	335	29
FTBR-72	72"	25"	34-1/2"	46	—	—	—	—	2500	475	43