

PROJECT \_\_\_\_\_  
 ITEM NO. \_\_\_\_\_  
 QTY. \_\_\_\_\_

**SOILED GLASS CENTER**

MODEL	LENGTH	DEPTH	SINK SIZE
<input type="checkbox"/> GWS-26	26"	24"	8 x 9 x 8D

**CLEAN GLASS CENTER**

MODEL	LENGTH	DEPTH	GLASS RACKS
<input type="checkbox"/> GWC-26	24"	24"	3

**STANDARD FEATURES**

- **ALL WELDED CONSTRUCTION** - fully welded, ground and polished to form one integral unit; no screws, pop-rivets or solder.
- **CORRUGATION** - 18 gauge #304 series 18-8 stainless steel full-length continuous "WWW" corrugation pitches to 1" brass drain and is reinforced with 4" wide 14 gauge s/s inverted U-channels welded underneath and sound deadened.
- **TOP** - 18 gauge #304 series 18-8 stainless steel.
- **BACK** - 18 gauge #304 series 18-8 stainless steel.
- **BOTTOM** - 18 gauge #304 series 18-8 stainless steel.
- **ENDS** - 18 gauge #304 series 18-8 stainless steel.
- **BACKSPLASH** - 18 gauge #304 series 18-8 stainless steel.
- **LEG ASSEMBLIES** - 14 gauge s/s channels with heavy-duty s/s gussets, 1-5/8" s/s tube legs and adjustable s/s bullet feet.
- **DECORATIVE POLISHED BULLNOSE**

**SOILED GLASS CENTER FEATURES:**

- Dump sink with strainer basket and faucet.
- Dry waste station with hinged door and plastic receptacle.
- Enclosed chemical cabinet with hose access right rear and bottom.

**CLEAN GLASS CENTER FEATURES:**

- Corrugated drainboard.
- Full cabinet.
- Adjustable glass rack storage slides for 20x20 racks 3 high.

**OPTIONS**

**SOILED GLASS CENTER OPTIONS**

- PR** -----hot spray pre-rinse faucet
- LSD** -----liquid soap dispenser installed in rear deck
- M** -----customized

**CLEAN GLASS CENTER OPTIONS**

- AS** -----adjustable intermediate shelf in lieu of glass rack slides
- M** -----customized

**Model Number Guide**

Use this guide to create the model specific to your needs.

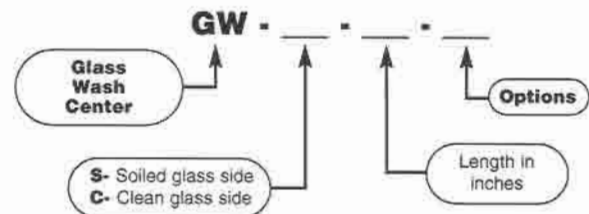



**GW MODELS**

*Soiled & Clean Glass Wash Centers*

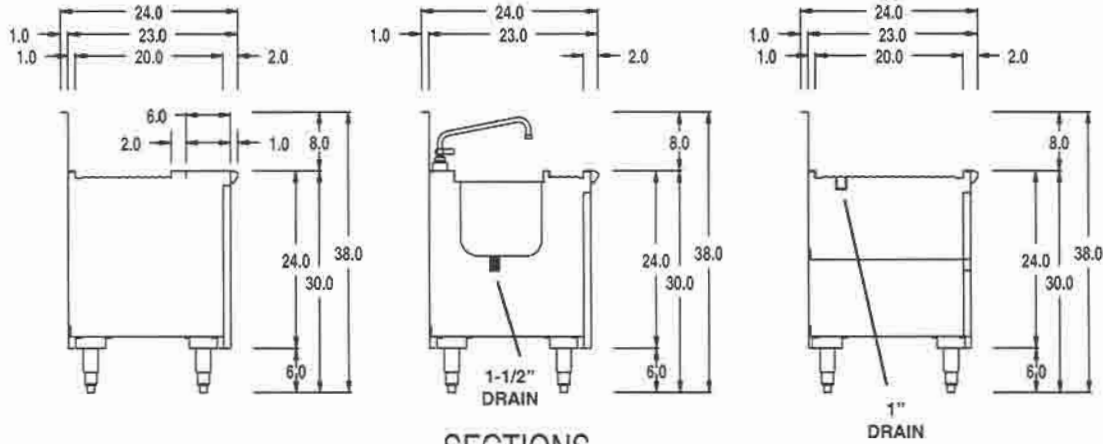

**SECTIONS**

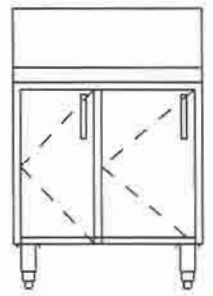
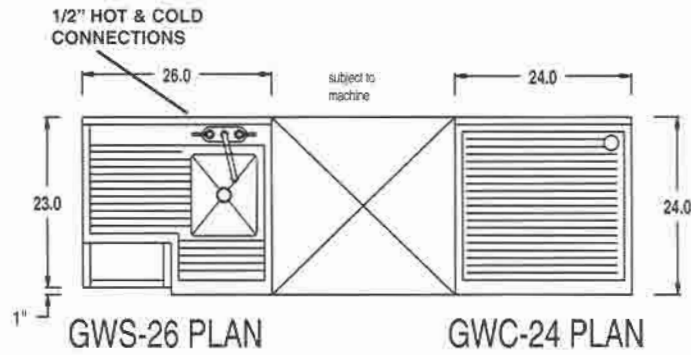

**GWS-26 ELEV.**

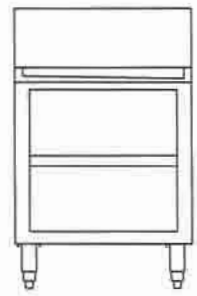

**GWC-24 ELEV.**

SOILED GLASS CENTER				CLEAN GLASS CENTER				SHIP WEIGHT	CUBE
MODEL	LENGTH	DEPTH	SINK	MODEL	LENGTH	DEPTH	RACK CAP.		
GWS-26	26"	24"	8 X 9 X 8D	GWC-24	24"	24"	3	130	16