

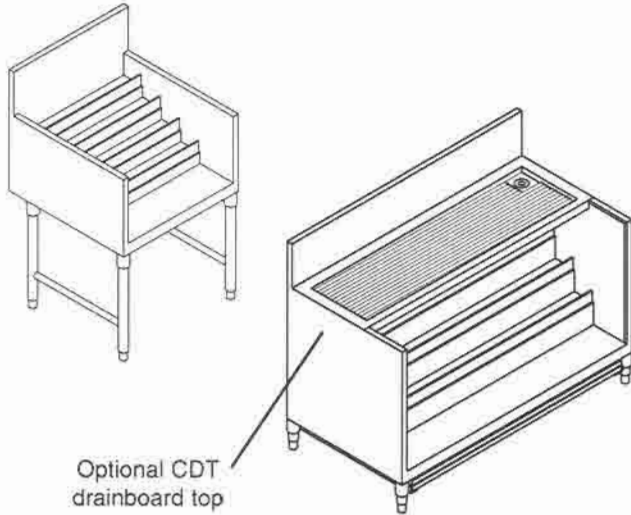

LS MODELS

Liquor Steps



Optional CDT
drainboard top

PROJECT _____
ITEM NO. _____
QTY. _____

CABINET STYLE

MODEL	LENGTH	STEPS	BOTTLE CAP.
<input type="checkbox"/> LSC-24	24"	4	34
<input type="checkbox"/> LSC-48	48"	4	64

WORKBOARD STYLE

MODEL	LENGTH	STEPS	BOTTLE CAP.
<input type="checkbox"/> LSW-12	12"	5	18
<input type="checkbox"/> LSW-18	18"	5	26

STANDARD FEATURES

- **ALL WELDED CONSTRUCTION** - fully welded, ground and polished to form one integral unit; no screws, pop-rivets or solder.
- **LIQUOR STEPS** - 18 gauge #304 series 18-8 stainless steel with bottle restraints.
- **TOP** - 18 gauge #304 series 18-8 stainless steel.
- **BACK** - 18 gauge #304 series 18-8 stainless steel.
- **BOTTOM** - 18 gauge #304 series 18-8 stainless steel.
- **ENDS** - 18 gauge #304 series 18-8 stainless steel.
- **BACKSPLASH** - 18 gauge #304 series 18-8 stainless steel.
- **LEG ASSEMBLIES** - 14 gauge s/s channels with heavy-duty s/s gussets, 1-5/8" s/s tube legs and adjustable s/s bullet feet.

OPTIONS

- SEC** -----two-piece security cover
- CDT** -----corrugated drainboard top
- M** -----customized

Model Number Guide

Use this guide to create the model specific to your needs.

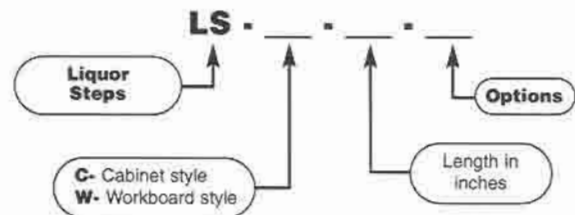



LS MODELS

Liquor Steps

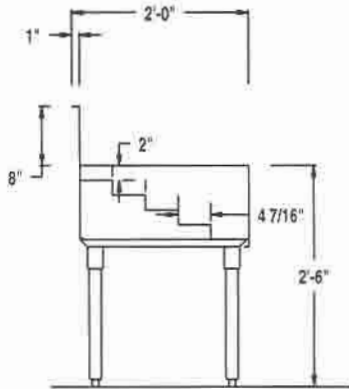

LSW SECTION

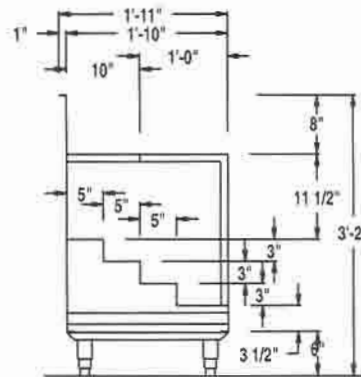

LSC SECTION



LSW PLAN

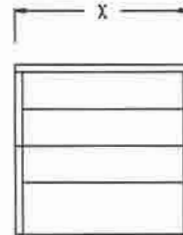

LSC PLAN

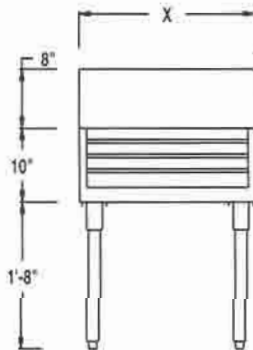

LSW ELEVATION

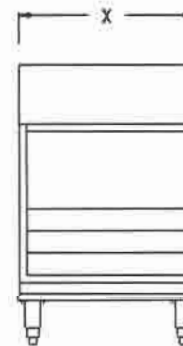

LSC ELEVATION

CABINET STYLE			BOTTLE CAP.	SHIP WEIGHT	CUBE
MODEL	LENGTH	STEPS			
LSC-24	24"	4	34	115	14
LSC-48	48"	4	64	205	28

WORKBOARD STYLE			BOTTLE CAP.	SHIP WEIGHT	CUBE
MODEL	LENGTH	STEPS			
LSW-12	12"	5	18	85	10
LSW-18	18"	5	26	110	15