



SHKR MODELS

Seafood & Shucking Center

with or without Base Refrigerator

PROJECT _____
 ITEM NO. _____
 QTY. _____

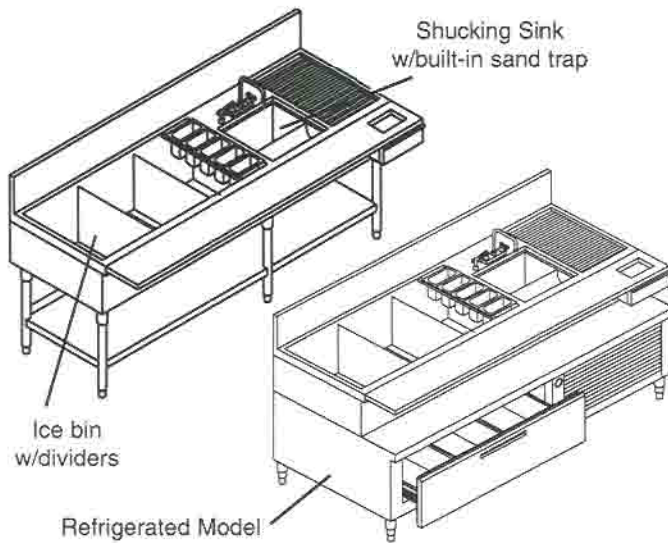

REMOTE MODEL	SELF CONTAINED MODEL	LESS BASE REFRIGERATOR MODEL	LENGTH
SHKRR-72	SHKRS-72	SHK-72	72"

ALL INCLUSIVE FEATURES:

- Shucking sink with built-in sand trap, H/C faucet and pre-rinse spray faucet
- Ice chest with perforated bottom and two movable dividers and stainless steel condiment cups
- Recessed top pitches to sink
- Full length white plastic cutting board
- Full length built-in plate shelf
- Model less base refrigerator comes standard with undershelf

STANDARD FEATURES

- **ALL WELDED CONSTRUCTION** - fully welded, ground and polished to form one integral unit; no screws, pop-riquets or solder.
- **EXTERIOR** - all 18 gauge #304 series 18-8 stainless steel.
- **ICE CHEST LINER** - 12-1/2" net deep, 18 gauge #304 series 18-8 stainless steel all welded with 3/8" radius corners, two movable dividers and s/s condiment cups.
- **INSULATION** - polyurethane shot-in-place foam (NO CFC's).
- **SHUCKING SINK** - 10 x 14 x 10" deep with built-in shell and sand trap, shucking trough, Chicago faucet, T&S pre-rinse spray faucet.

BASE REFRIGERATOR MODELS INCLUDE:

- **MEGABILT DRAWER SYSTEM** - accomodates three 12x20x6" deep pans side by side. Exclusive 14 gauge stainless steel drawer track system with tandem 2" all s/s skate wheels.
- **PLATE SHELF** - 10" deep 18 gauge #304 series 18-8 stainless steel with decorative polished bullnose.
- **SELF-CONTAINED REFRIGERATION** - fully balanced hermetic condensing unit is provided with evaporator coil, TX valve, thermostat, gravity defrost system and condensate evaporator. Condensing unit will be on right unless otherwise specified.
- **REMOTE MODELS** - include all of the above with the exception of condensing unit and condensate evaporator pan. Expansion valve shipped loose. No pre-wiring.

OPTIONS

- CB** -----cabinet base
(for center less base refrigerator only)
- M** -----customized
- PP** -----Pre-piped & pre-wired. Refrigeration, plumbing and electrical will be stubbed out at required location by specifying one of the following: LE-left end, RE-right end, BL-back left, BR-back right.

Model Number Guide

Use this guide to create the model specific to your needs.

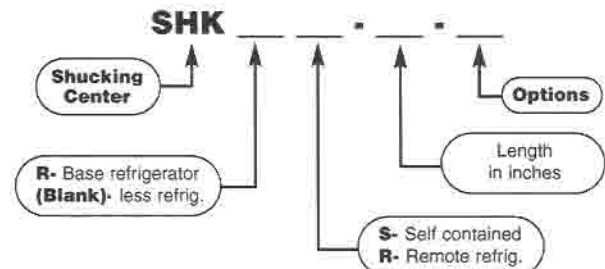



SHKR MODELS

Seafood & Shucking Center

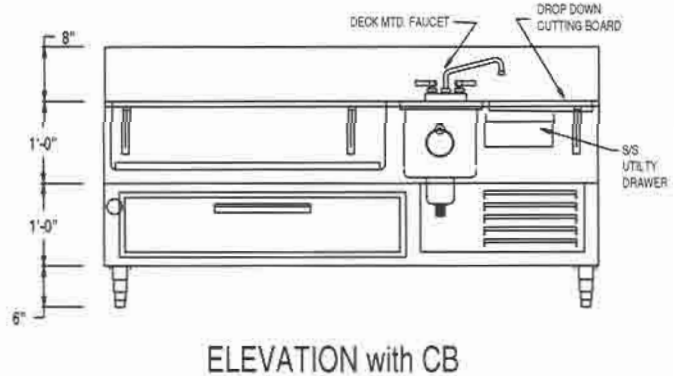
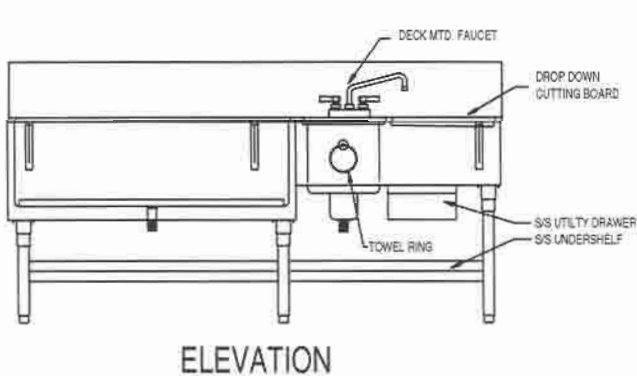
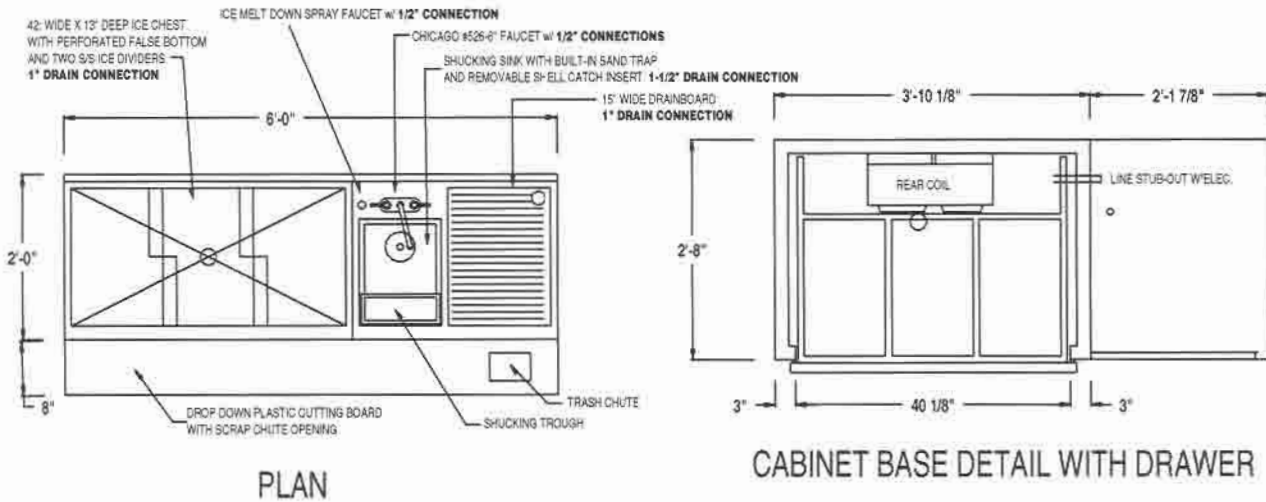
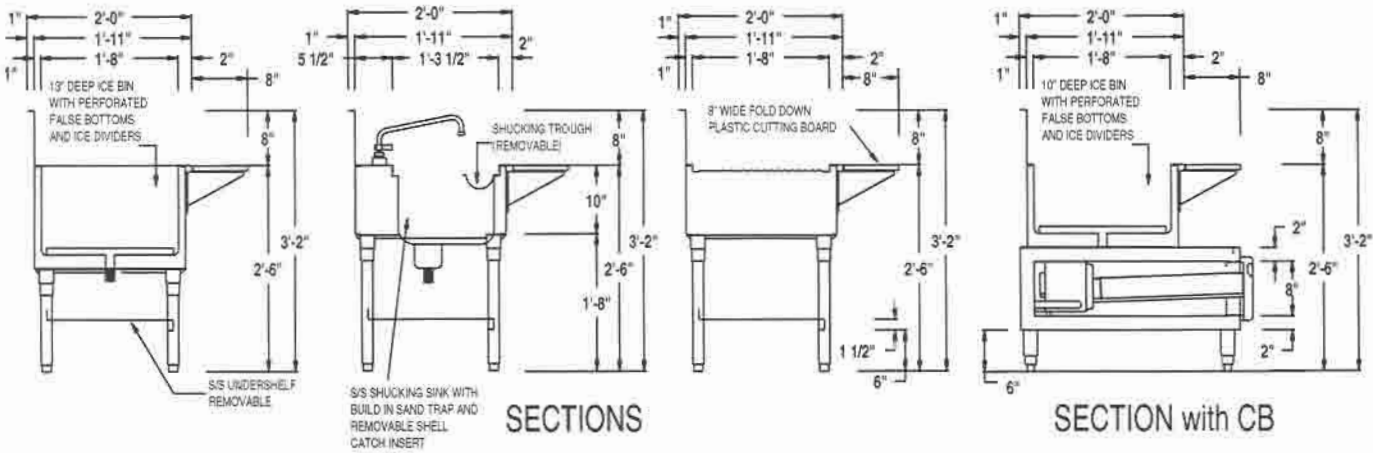

SELF-CONTAINED REMOTE LESS REFRIG.	MODEL NUMBER	O.A. LENGTH	O.A. DEPTH	O.A. HEIGHT	H.P.	VOLTS	AMPS	PHASE	BTU'S	SHIP	
										WEIGHT	CUBE
	SHKRS-72	72"	34"	36"	1/4	115V	8.9	SINGLE	—	600	75
	SHKRR-72	72"	34"	36"	—	115V	1.7	SINGLE	1300	510	75
	SHK-72	72"	34"	36"	—	—	—	—	—	300	54